

CORE

MINI | Digital Pressurisation Units

Suitable for maintaining pressure in large domestic and small commercial sealed heating systems, chilled water systems, refrigeration units and industrial cooling systems.

Mini units are exceptionally easy to install and commission and are housed in a compact and robust enclosure suitable for wall mounting.

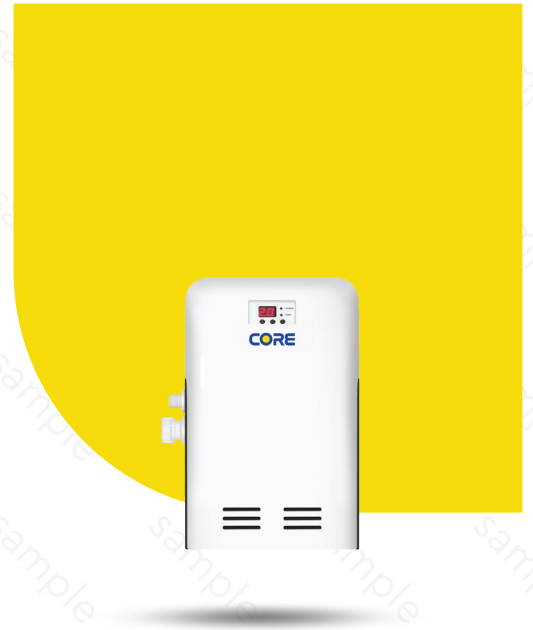

Features

- Suitable for sealed systems of up to 6,000 litres
- Single (Duty) or twin (duty-standby) pump options
- 3.0 bar cold fill pressure
- 2 litre tank capacity
- Compact design, wall mounting
- Digital control system and LED display
- Automated system top-up
- Easy to install and set up
- High flow, WRAS approved fill valve
- Outlet configurable for left or right connection with flexible hose (supplied)
- Category 5 backflow protection, Type AB air gap, weir overflow and warning pipe
- Patent protected
- 2 year warranty

Applications

- Maintaining system pressure in large domestic and commercial sealed heating systems
- Maintaining system pressure in chilled water systems, refrigeration units and industrial cooling systems

Pump Model		SPU 130 Mini 46719	SPU 230 Mini 46720
General	Warranty	2 years	
	Conformity certification	UKCA / CE	
Features	System capacity	Up to 6,000 litres	
	Mounting	Wall mount	
	Pump control system	✓	✓
	Intelligent control interface	✓	✓
	System fill mode	-	-
	Dry run protection	✓	✓
	Typical noise	60 dB(A)	60 dB(A)
Materials	Break tank	Polyethylene	
	Front cover	Acrylic capped ABS	
Performance	Maximum fill pressure	3.0 bar (300 kPa)	
	Maximum flow	1 l/min	
	Maximum inlet pressure - tank fill valve	7 bar (700 kPa)	
	Maximum working pressure	6 bar	
	Ambient air temperature	Min 4 °C / Max 40 °C	
	Relative humidity	95 % non-condensing	
	Min./Max. water temperature	Min 4 °C / Max 23 °C	
Water tank	Usable water capacity	2 litres	
	Inlet valve and fill rate	Torbeck (side entry) 12 l/min	
	Fluid category	CAT 5 (type AB air gap with weir)	
Connections	Cold water inlet	G ½ male	
	Cold water outlet (flexible hose)	15 mm compression x 600 mm flexible hose	
	Overflow	G ¾ (19 - 23 mm diameter pipe compression fitting)	
Pump	Number of pumps	1	2
	Pump mode	Duty	Duty-standby
	Pump type	Piston	
	Motor type	Solenoid	
	Duty rating (unit)	Int 30 mins on/30 mins off (S3)	Continuous (S1)
	Pump head and seal	PA66/POM	NBR
Electrical	Power supply (Vac/Ph/Hz)	230 V a.c. / 1 / 50 Hz	
	Power consumption - P1	100 Watts	
	Current - full load	0.5 Amps	
	Fuse rating	5 Amps	
	Power cable length	1.5 metres (pre-wired)	
	Alarm output	Single	
Physical	Enclosure protection	IPX4	
	Width	293 mm	
	Depth	145 mm	
	Height	403 mm	
	Weight - including fittings	3.6 Kg	4.2 Kg
	Weight - filled	6.6 Kg	7.2 Kg

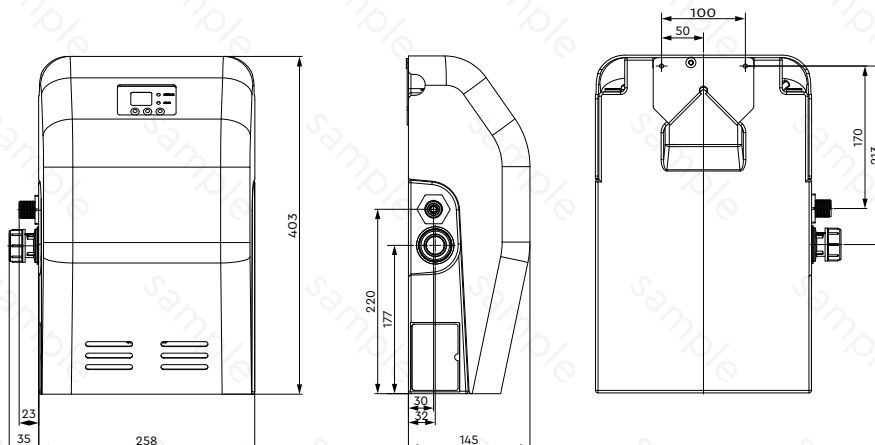

Smith Brothers Stores Limited reserves the right to amend specifications without notice.

SBS, Unit V2, Winchester Avenue, Blaby, Leicester. LE8 4GZ, UK

Tel: +44 (0) 1162 227330 | Fax: +44 (0) 1162 227330

www.sbs.co.uk | For any sales enquires contact: sales@sbs.co.uk

Pt. No. 72166 Issue 2022-01-01